

Mounting instructions for digger „tollo“

Item-No. 51 1100 402



Diagram 1: Overall view of the play equipment

Mounting instructions for digger „tollo“

Item-No. 51 1100 402

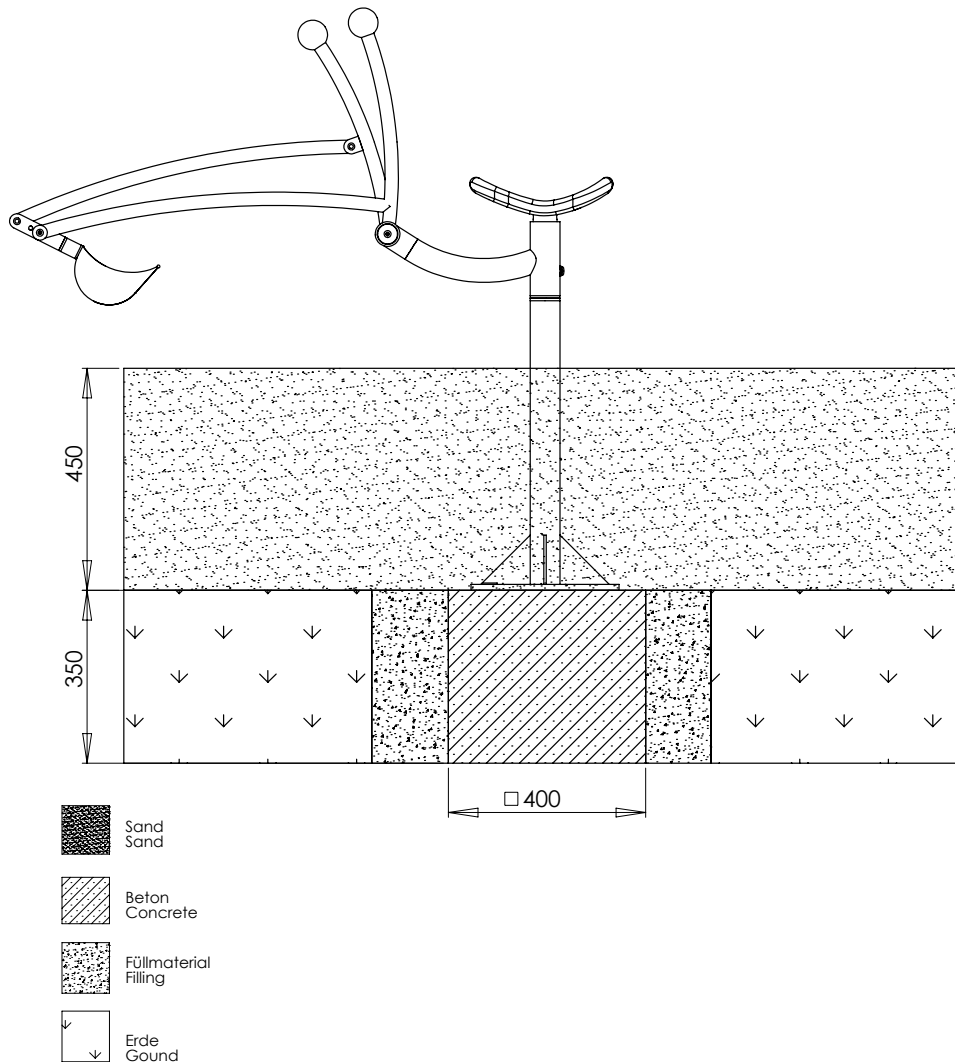

Diagram 2: Side view with dimension details „tollo“

1. Select the play equipment location in consideration of the required safety area (see Diagram 3: \varnothing 5500 mm).
2. The impact area of a playground equipment with an enforced movement is not allowed to overlap the impact area of other equipment.
Regarding to DIN 1176 - 4.2.8.2.5, impact absorbing surfaces have to be put under the whole impact area of every equipment with an enforced movement.
3. Carry out excavation work for the foundation anchor as shown in Diagram 2. After excavation, compress the foundation floor.
Note: The play equipment is built in on the play level.
4. Set up the concrete foundation acc. to the dimensions (LxWxH 400 x 400 x 350mm) indicated with central, horizontal reinforcement.

Reinforcement plan: Concrete foundation with reinforcement

Main foundation: BSt 500S

Ever 4 stirrups \varnothing 8 mm lengthwise and cross

Concrete cover $h' = 3$ cm

Concrete quality class B25

5. During the setting period of 10 -14 days - depending on weather conditions and foundation size - do not allow to use the equipment.

Mounting instructions for digger „tollo“

Item-No. 51 1100 402

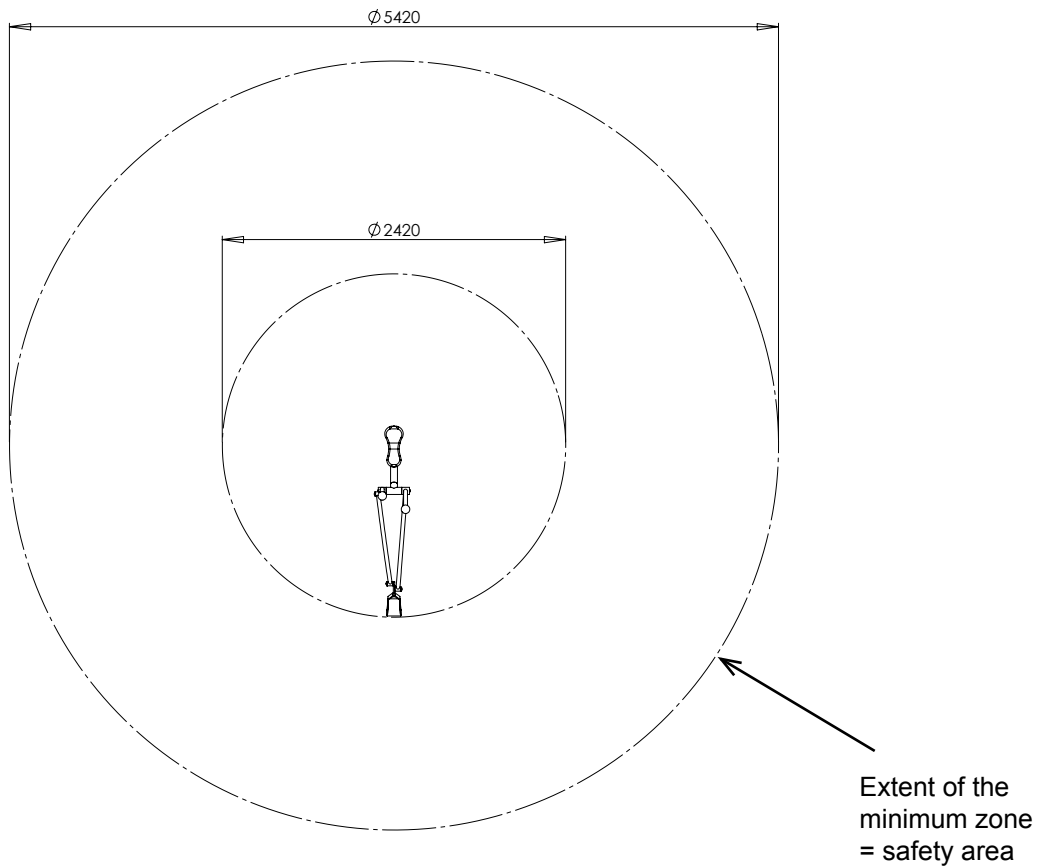

Diagram 3: Top view „tollo“

6. After the setting clean the surface of the foundation, place the pre-mounted play equipment onto it and screw the base plate onto the foundation anchor with the included heavy-duty dowel M10.
7. Seal the foundation with the safety cover required for the height of fall indicated (critical drop height ≤ 1000 mm). Set up impact-absorbing playground surfacing according to EN 1176-1, table 4.
Recommended surface material: sand
8. Do not allow to use the equipment before the installation has been finished.
9. **Attention:** If the play equipment has been incompletely installed or partly dismantled when carrying out maintenance and repair work, this may lead to particular risks of injury for the user. For this reason, make clearly visible that the equipment shall not be used in such cases.
10. **NOTE:** Play equipment, which contain components made of stainless steel should not come with „normal“ steel parts in contact. Those steel parts may rub off and leave small steel particles in combination with moisture brown rust stains. If such corrosion occur on stainless steel parts, they are fine with an abrasive (240 grit) to remove.
Please take care when transporting and setting up the fact that the components are made of stainless steel with no „normal“ steel parts in contact.

Mounting instructions for digger „tollo“

Item-No. 51 1100 402

In order to preserve a good visual appearance of your stilum playground equipment over a long period one should take care of maintenance of the stainless surface even despite of their corrosion resistance.

Especially areas, which can not be reached by rainfall should be frequently cleaned from dirt and deposits due to air pollution and dirt caused by the atmosphere.

Light soiling can easily be removed by using a high pressure cleaner.

For persistent deposits use a clean cloth moistened with a special liquid cleaner (e.g. on phosphoric acid) and rinse off with clear water after a short application time. During cleaning with mild abrasive components, only wipe over stainless steel surface in polishing direction.

For heavily soiled surfaces, polishes can be used (e.g. for cleaning chrome on cars) or for greasy and oily dirt alcoholic cleaning agents and solvents (e.g. ethyl alcohol, isopropyl alcohol or acetone).

However, it should be noted that the dissolved soiling is not spread over the surface again.

Do not use any chlorid or hydrochloric containing cleaning products nor scouring powder, bleaching - or silver polish cleaner. Cleaning intervals depend on type and degree of soiling as well as on demands made on optical characteristics.

Therefore cleaning is advisable at intervals of six to twelve months – whereby in the case of strong soiling it is appropriate to clean the playground equipment at intervals of 3 to six months.